



[www.mazzer.com](http://www.mazzer.com)



KONY ELECTRONIC





COLOURS



**MACINADOSATORE KONY  
ELETTRONICO CON MACINE CONICHE**

REGOLAZIONE DI MACINATURA  
MICROMETRICA CONTINUA

- Macinatura istantanea
- Regolazione elettronica della dose
- Ventilazione elettronica

**CARATTERISTICHE TECNICHE:**

Potenza	450 Watt
<b>Macine coniche</b> (rif. 191C)	Ø 63 mm
Giri macine	420 (50 Hz) g/min 500 (60 Hz) g/min
Capacità contenitore caffè in grani	1,3 Kg
Peso netto	20 Kg



**GRINDER-DOSER KONY ELECTRONIC  
WITH CONICAL GRINDING BLADES**

STEPLESS MICROMETRICAL  
GRINDING ADJUSTMENT

- Grinding on demand
- Electronic dose adjustment
- Ventilation with electronic control

**CARATTERISTICHE TECNICHE:**

Power	450 Watt
<b>Conical grinding blades</b> (ref. 191C)	Ø 63 mm (2½ inches)
Grinding blade speed	420 (50 Hz) r.p.m. 500 (60 Hz) r.p.m.
Coffee-bean container capacity	1,3 Kg (2,9 lbs)
Net weight	20 Kg (44 lbs)



**MOULIN DOSEUR KONY  
ÉLECTRONIQUE AVEC MEULES CONIQUES**

RÉGULATION DE MOUTURE  
MICROMÉTRIQUE CONTINUE

- Mouture instantanée
- Réglage électronique de la dose
- Ventilation électronique

**CARACTÉRISTIQUES TECHNIQUES:**

Puissance	450 Watt
<b>Meules coniques</b> (réf. 191C)	Ø 63 mm
Tours meules	420 (50 Hz) tr/min 500 (60 Hz) tr/min
Contenance de la trémie	1,3 Kg
Poids net	20 Kg



**DOSIERMÜHLE KONY ELEKTRONISCH  
MIT KONISCHE MAHLSCHEIBEN**

STUFENLOSE MIKROMETRISCHE  
MAHLREGELUNG

- Augenblickliches Mahlen
- Elektronische Einstellung der Dosis
- Elektronisch-kontrollierte Luftung

**TECHNISCHE DATEN:**

Leistung	450 Watt
<b>Mahlscheiben konischen</b> (Kennziffer 191C)	Ø 63 mm
Mahlscheibenumdrehungen	420 (50 Hz) r.p.m. 500 (60 Hz) r.p.m.
Kapazität des Bohnenbehälters	1,3 Kg
Nettogewicht	20 Kg



**MOLINO DOSIFICADOR KONY  
ELECTRÓNICO CON FRESAS CONICAS**

REGULACIÓN MOLIENDA  
MICROMÉTRICA CONTINUA

- Molidura instantánea
- Regulación electrónica de la dosis
- Ventilación electrónica

**DATOS TÉCNICOS:**

Potencia	450 Watt
<b>Fresas conicas</b> (ref. 191C)	Ø 63 mm
Revoluciones fresas	420 (50 Hz) r.p.m. 500 (60 Hz) r.p.m.
Capacidad de la tolva	1,3 Kg
Peso neto	20 Kg



**MOINHO DOSEADOR KONY  
ELECTRÓNICO COM MÓS CONICAS**

REGULAÇÃO DA MOAGEM  
MICROMÉTRICA CONTÍNUA

- Moagem instantânea
- Regulação electrónica de dose
- Ventilação electrónica

**DADOS TÉCNICOS:**

Potencia	450 Watt
<b>Mós conicas</b> (ref. 191C)	Ø 63 mm
rotações dos mós	420 (50 Hz) r.p.m. 500 (60 Hz) r.p.m.
Capacidade tremonha	1,3 Kg
Peso líquido	20 Kg

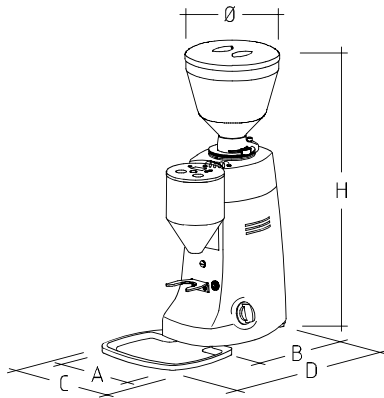

	mm	inches
A	206	8 ¼
B	263	10 ½
C	240	9 ½
D	420	16 ½
H	650	25 ½
Ø	212	8 ¼

CERTIFICATIONS



• Il costruttore si riserva la facoltà di apportare quelle modifiche tecniche che si rendessero necessarie senza preavviso. • The manufacturer reserves the right to change specifications without notice. • Le constructeur se réserve le droit d'effectuer des modifications sans aucun préavis. • Der Hersteller vorbehalt sich den technischen Daten wamunglos zu ändern. • El constructor se reserva el derecho de efectuar sin previo aviso las modificaciones que considere oportunas en interés de mejoras técnicas en sus fabricados. • O constructor reserva-se o direito de modificar sem aviso previo as máquinas tratadas neste manual.

www.mazzer.com

MAZZER LUIGI s.r.l. Via Moglianese, 113 - 30037 Gardigliano di Scorzè (VE) - Italy  
Tel. +39 041 5830200 - +39 041 5831300 - Fax +39 041 5830060 - E-mail: mazzer@mazzer.com - C.F. e P. IVA 00165200270



ISO 9001:2008  
n. 9130.MAZZ